



PLOWING FORWARD

KAGE QUALITY GUARANTEE

When you purchase a KAGE product, we want you to be confident you're buying the best equipment possible. We back our products with a 15-day trial guarantee. From the date of delivery, you have 15 days to try out the product and if you're not satisfied, you can return it - no questions asked. KAGE will reimburse 100% of the purchase & shipping costs.*

BUILDING IT BETTER

If the idea isn't revolutionary or innovative as our company name states, we're not taking the idea far enough. KAGE Innovation invents and manufactures equipment for the professional grounds manager. Our core objective is to offer new products as solutions to common industry setbacks. In short, we're always on the lookout for "the better way."

WHAT'S IMPORTANT

Our customers and employees.

KAGE Innovation is run by people, and we serve people. The company was started because of an opportunity that was seized. KAGE Innovation continues to create opportunities for people - both customers and employees alike.

DRIVING NEW IDEAS TO THE INDUSTRY

Have you ever thought, "There just has to be a better way!" Applying our Experience Driven Innovation to conquer those ideas is what we do. Every week new ideas are hashed out and the ones that make it earn the KAGE stamp for excellence in design.

As our business has flourished, our mindset has not changed. It is still much like when I started out tinkering in my dad's workshop 12 years ago. Persevering until we find the better way, and designing with the end-user in mind. As we grow and the number of KAGE employees grow, our collective vision can be summed up in one sentence; "We want to make it easy for you".

Ours is a timeless industry. Timeless because there has, and always will be, grass to mow and snow to push. The caveat is that time is of the essence. In this industry the only variable is time, and we all need more of it. Time is expensive, and as labor costs increase we're pushed to work smarter and faster. It's this void where we seek to make the difference.

"Whatever you do, work heartily, as for the Lord and not for men"
- Colossians 3:23

Mike Stephan
PRESIDENT & FOUNDER



CONTENTS

Snow Systems

- 3 SnowFire/Skidsteers
- 5 SnowFire/Compacts
- 7 SnowStorm
- 9 ShadowBlade

AG Mounts

- 11 Tractor Mounts

Snow Tires

- 13 KageKlawz

Anti-Icing

- 15 LiquidRage

Flexible Cutting Edge System

- 17 AdvantEdge

Lawn Management

- 19 WheelKaddy

Snow Management

- 21 Snow Stakes
- 21 BuddyStrap
- 22 Poly Rotor Paddles
- 22 SnowBlaze Shovel

Plow Accessories

- 23 Curb Guard Kit
- 23 Polyurethane Cutting Edge Kit
- 23 Back Drag Kit
- 23 Plow Guides
- 24 WingLine™ - Laser Plow Guide

Specifications

- 25 SnowFire/Skidsteer/Compacts Specs
- 26 SnowStorm Specs
- 27 SnowFire Quick Connect Specs
- 28 SnowStorm Quick Connect Specs
- 29 ShadowBlade Specs
- 30 Tractor Mounts Specs
- 31 KageKlawz Specs
- 32 LiquidRage Specs
- 33 AdvantEdge Specs
- 34 WheelKaddy Specs

LEGEND

-  Skidsteer
-  Telehandler
-  Compact Wheel Loader
-  Wheel Loader
-  Compact Loader Backhoe
-  Loader Backhoe
-  3-Point Tractor
-  Rear 3-Point Tractor
-  Municipal Truck
-  Commercial Walk-Behind Mower

* The money back guarantee reimburses 100% of the purchase & shipping costs. However, all return shipping and shipping arrangements are the responsibilities of the original purchaser.

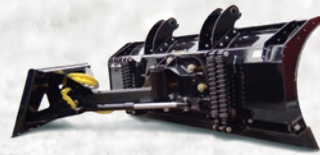

THE BLADE

>Plow structure like no other in its class with an attack angle of 65 degrees

>Moldboard sheet itself is built with 10-gauge GRADE 50 steel to extend the life of the plow

>Blade features a standard 8" safety trip-edge that prevents accidental damage when encountering hidden obstacles by tripping back 68 degrees



THE BOX

>Bullet proof structure that conquers the destructive tendencies of any snow removal operation

>Self-adjusting, flexible polyurethane skids. They have the ability to slide upwards as the cutting edge of the plow becomes worn, allowing it to cleanly scrape the plowing surface

>10" wide snow catches to prevent spillage while pushing



UNIVERSAL SKIDSTEER MOUNT

The Universal Skidsteer Mount is the standard for the SnowFire System. This couples to any modern skidsteer in seconds. Then, just couple the hydraulic couplers to the machine auxiliary hydraulic and you are ready to roll snow!



FROM BOX TO BLADE IN SECONDS

The SnowKage Box hooks onto a skidsteer snow plow to instantly create a revolutionary containment system. This is done in seconds without leaving the cab - no pins, bolts or hinges.

Attaching & detaching the box can take less than 5 seconds for a skilled operator to do.

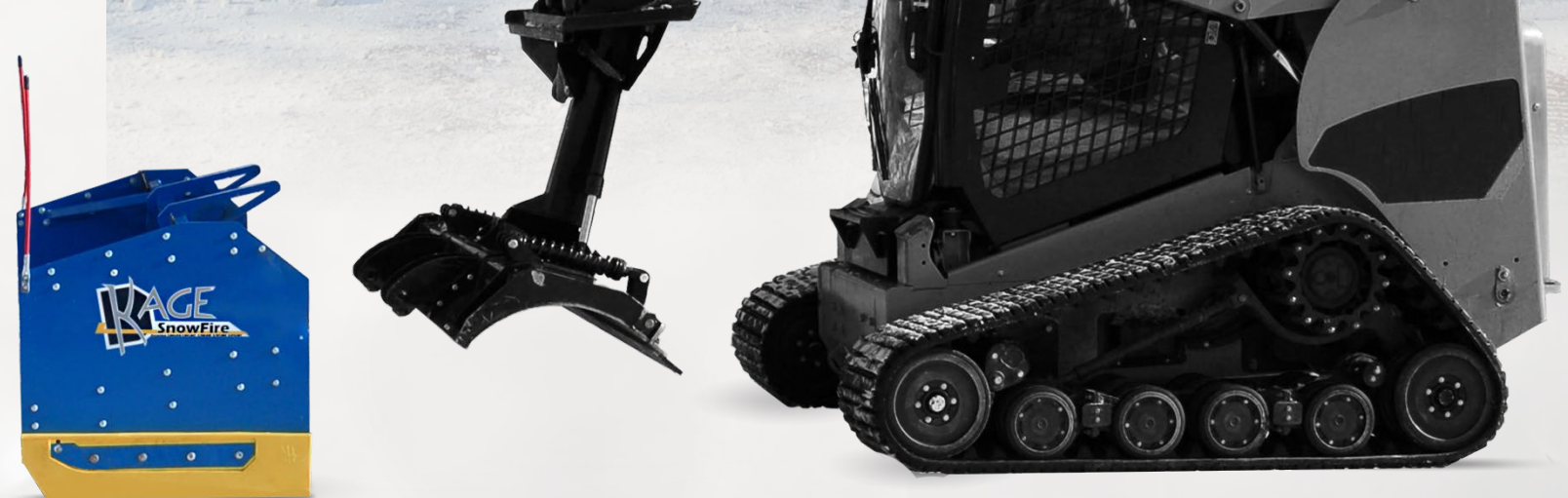

TO ORDER CALL 651-433-4628, OR GO ONLINE: KAGEINNOVATION.COM

See Specifications on Page 25

SNOWFIRE/COMPACTS

SNOW PLOW SYSTEM PATENT PROTECTED



OVERBUILT BY DESIGN



MULTIPLE CARRIER ATTACHMENTS

This system can incorporate many different styles of hook-and-pin style attachments OR universal skidsteer attachments. See attachment options on page 27.



FLOATING TOP LINK

Uniquely designed for compact wheel loader applications, this attachment allows the plow to float while driving over uneven terrain. This hitch style is recommended for all wheel loader applications because it increases the ability to steer the loader, and the scraping ability of the plow. For available Quick Attaches see our specification tab.

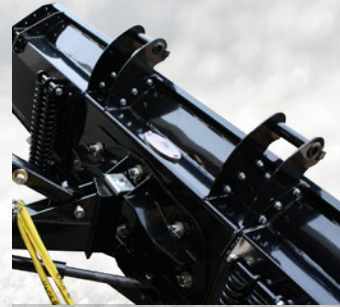

SNOW PUSHER CAM LOCK

The simple and sturdy way to attach the SnowKage to the blade from inside your skidsteer cab is by using a cam locks. Raise the boom up and tilt the plow down behind the hooks of the SnowKage, align cam lock brackets of the blade with the receptor hooks of the SnowKage and raise the boom.... then back to work! This is done in about 5 seconds. Back and forth from plowing to pushing.



THE PAYOFF

- >Reduce plow time by 25% to 50%
- >Advantages of a snow plow and a pusher box combining them into one fast and seamless operation
- >Windrow or back drag with the plow normally, then grab the box to push out their piles or windrows



SNOWSTORM

SNOW PLOW SYSTEM PATENT PROTECTED



BUILT TO LAST



BOLT-ON UNDERCARRIAGE KITS FOR TRACTORS

Everyone knows tractors are versatile, fuel efficient machines. Combined with a SnowStorm series plow system, tractors can be far more useful for your business year round. Each undercarriage kit comes with an owners manual to help you mount the unit in short time.



CONSTRUCTED WITH HIGH GRADE STEEL

The SnowStorm blade is designed specifically to take the abuse from mid-sized wheel loaders, backhoe loaders, tele-handlers and agricultural tractors. The link, the blade and SnowKage mate perfectly creating the ultimate snow containment tool. The hydro-lock brackets of the blade latch onto the bars of the box. Controls in the cab allow the operator to remain in the cab until the job is done.



THE BLADE

The SnowStorm blade cuts clear down to the plowing surface with the aid of an oscillating mount. The blade also comes with a standard trip-edge which is backed up with 8 compression springs and a tri-formed box.

THE BOX

Tough, triangulated supports mean that you can push this to the extreme with no breakdowns. On both sides of the box are 2-inch poly skids designed to go easy on curbs. The box width manually adjusts from 10 feet out to 14 feet.



TO ORDER CALL 651-433-4628, OR GO ONLINE: KAGEINNOVATION.COM

See Specifications on Page 26



OPTIONAL LASER GUIDANCE

The optional laser guidance reminds the operator when the ShadowBlade is deployed off to either side.



3-POINT SNOW ATTACK

We're building our reputation on being an innovator for the snow-removal industry. The ShadowBlade is a patented 3-point rear attachment design. This new weapon will set your tractor up to be a worthwhile year-round investment.



SIMPLE JOYSTICK CONTROL

Simple joystick control eases the operators ability to control both front and rear plow systems.



HYDRAULIC VALVE CIRCUIT

Located at the rear of the tractor up high for easy access, the hydraulic valve circuit, stays clear of compacted snow.



TO ORDER CALL 651-433-4628, OR GO ONLINE: KAGEINNOVATION.COM

See Specifications on Page 29

TRACTOR MOUNTS BOLT-ON UNDERCARRIAGES



KAGE TOUGH

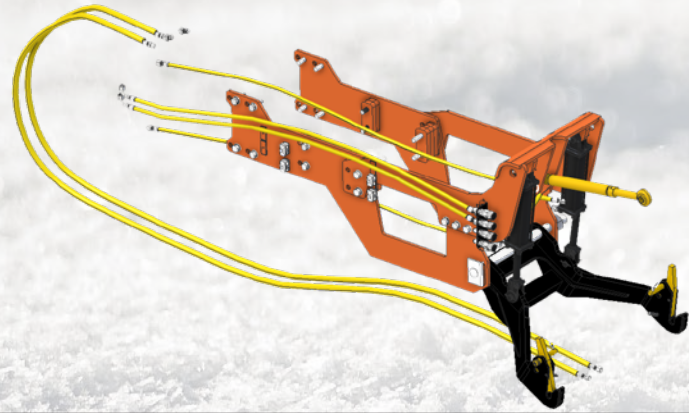

REVOLUTIONARY DESIGN

Let's have a conversation about the fuel efficiency of a tractor, the maneuverability of a tractor, the comforts of a tractor cab, and the superior traction and power of a tractor.

Then let's talk about mounting the world's best plow on the front of that tractor. Now that's something worth talking about! KAGE has harnessed the versatility of using a tractor for snow plowing by designing a bolt-on undercarriage mount for their signature plow systems. Our tractor mounts are built to handle the rigors of massive snow removal.

MORE VISIBILITY

With the low profile attachment of the KAGE Plow System and the undercarriage, the tractor and plow are more maneuverable and visibility is vastly improved over the use of loader arms.

FLOAT MODE

Maintain full down pressure while still easily plowing over contoured surfaces with the float mode.



- SNOWFIRE/
SKIDSTEER
- SNOWFIRE/
COMPACTS
- SNOWSTORM
- SHADOWBLADE
- TRACTOR
MOUNTS
- KAGEKLAWZ
- LIQUORAGE
- ADVANTEDGE
- WHEELKADY
- SNOW
MANAGEMENT
- PLOW
ACCESSORIES

TO ORDER CALL 651-433-4628, OR GO ONLINE: KAGEINNOVATION.COM

See Specifications
on Page 30



HORSEPOWER'S NOT THE ISSUE

We've done the side by side tests and there's no comparison in performance between conventional skidsteer tires and the KageKlawz. Even in a downward sloped drive, the results were obvious - the traction of the KageKlawz proved to be the game changer for skidsteer snow removal. You have all the power you need, now you just to put it to better use.

RADIAL VS BIAS TECHNOLOGY

MICHELIN[®] XM+S4 Pre-mold Retread Tires are the best performing snow tire tread on the market. They come with a Tread-Life Warranty* serviceable at any Michelin Retread dealer near you which will minimize down time — and with retreads, you may never need to buy a set of replacement tires again.

*Michelin Pre-mold Retread Tires are warrantied for the life of the tire, or down to 2/32 which is the legal limit. Search on-line for a certified Michelin retread tire dealer near you.



MICHELIN XM+S4 RETREADS

These tires allow the machine to transfer more power to the ground and absorbs more shock from uneven surfaces.



PROTECTED VALVE SYSTEM

Wheels come standard with welded valve protector.



TO ORDER CALL 651-433-4628, OR GO ONLINE: KAGEINNOVATION.COM

See Specifications on Page 31

LIQUIDRAGE ANTI-ICING SPRAY TECHNOLOGY PATENT PENDING



LESS ICE, CLEANER SURFACE



TOP 10 REASONS TO USE LIQUID ICE CONTROL

1. Liquid products are better for turf, soil, and ground water
2. Liquids do not bounce off your target coverage area
3. Liquid anti-ice applications do not 'plow off'
4. Liquids almost completely eliminate tracking into buildings and reduce corrosion and build up
5. Liquid anti-icing applications prevent ice bonding to the pavement
6. Liquids are easier to pump than dry salt is to scoop
7. Liquid blended products include corrosion inhibitors which lengthens equipment life
8. It takes 10x more resources to post de-ice than pretreat with liquid
9. Dry salt stops working at 10-15 degrees F
10. It takes 20 minutes for dry salt to start working at 25 degrees F



ADVANTAGES AND FEATURES

Anti-icing liquids are becoming all the rage. Use fewer solids to get the job done, and provide your customers with top-notch service.

The LiquidRage enables you to apply brine and other chemicals from your skid steer or tractor, without the need to buy expensive adapters and other equipment.

Features:

Adaptable to skidsteers and ag tractors (universal skid steer attachment, CAT II 3-Point Hitch attachment)

- >Fully enclosed design protects critical components
- >150 gallon capacity
- >Up to 8 foot spray width
- >Less than 36" wide

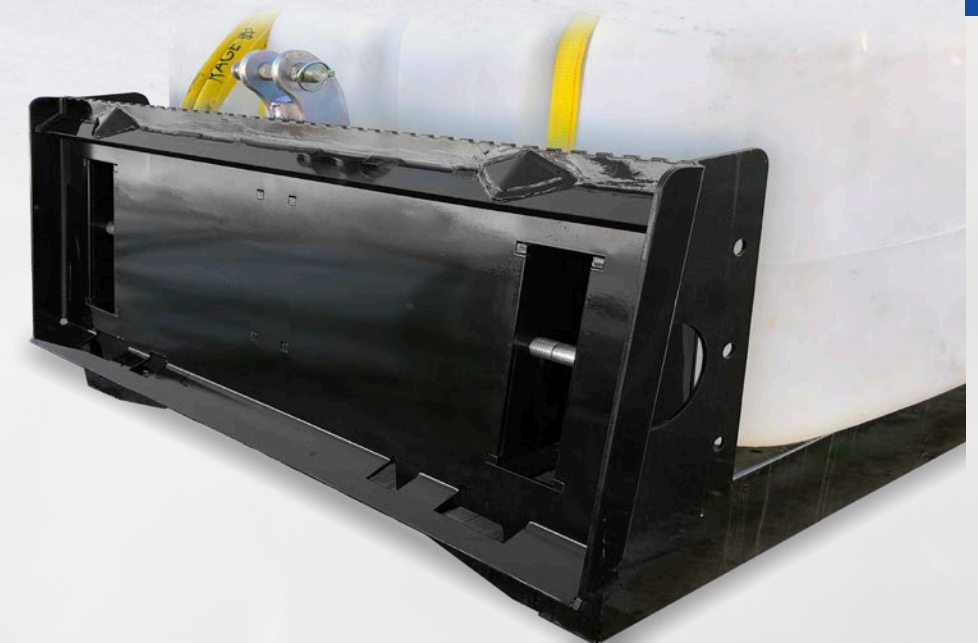

TO ORDER CALL 651-433-4628, OR GO ONLINE: KAGEINNOVATION.COM

See Specifications
on Page 32

ADVANTEDGE FLEX CUTTING EDGE SYSTEM PATENT PENDING



UNIVERSAL MOUNT



FRONT AND WING BLADE FLEX EDGE SYSTEM

Until now, sectional plows and cutting edges have only been available on a few brands of plows. The AdvantEdge™ makes it possible to harness sectional cutting edge technology on almost any plow or pusher available on the market today!



REDUCES DAMAGE TO PLOWED SURFACES

The AdvantEdge reduces the damage to curbs, asphalt/concrete transitions all while scraping better!

Each 18" or 24" cutting edge section is milled from the proprietary Hardox™ wear-plate, common to the mining industry for abrasion resistance and strength. Compared to carbide cutting edges, Hardox is not as brittle, and does not require any additional backing plates.

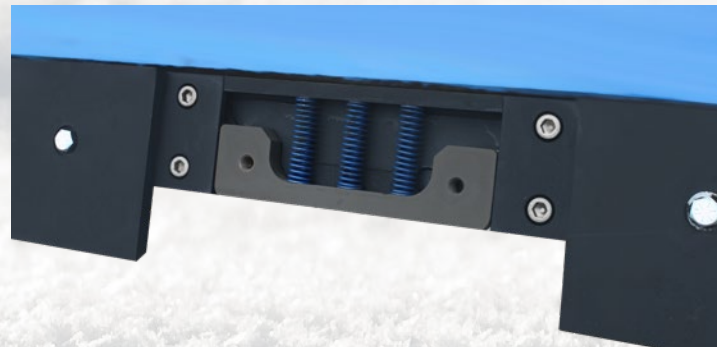

AUTOMATICALLY NAVIGATES PEAKS AND DEPRESSIONS

No pavement is perfectly flat, so unless your cutting edge is flexible, you're leaving snow behind. The independent cutting edge sections of the AdvantEdge help the blade to contour to the shape of any surface. The more snow you can remove during your plowing operations, the less salt and sand usage you'll have.

PRESSURE ADJUSTABLE ENCAPSULATED DESIGN

This patent pending design gives you the flexibility to adjust the pressure on each section so you can obtain just the right amount of preload. Each section is equipped with multiple 120 lb/inch die springs. AdvantEdge uses a closed face design reducing the impact that salt, sand, and ice can have. Each section is completely covered by the cutting edge, which is easily replaced by removing two bolts.



WHEELKADDY COMMERCIAL MOWER SULKY

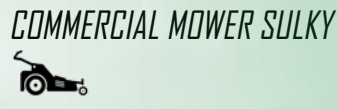

COMMERCIAL GRADE

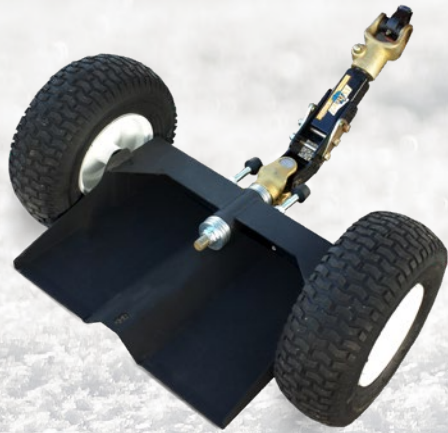

SULKY

We designed the KAGE WheelKaddy with two things in mind: Increased life expectancy, and reduced down time. That is why this sulky utilizes automotive-grade components, such as tapered roller bearings, drive-train (PTO) pivot yokes, and a grade 50 steel platform. Experience less down time plus a more comfortable ride because of our designed-by-the-user approach!



250 SERIES

Simple and durable. The economic model that gives you the lowest maintenance sulky ever.



500 SERIES

The original. Simple, yet packed with features and as durable as they come! The 500 series features a very smooth ride with the unique suspension.



360 SERIES

The 360 Series swings 360 degrees for backing up without damaging turf. This model features suspension, longevity, and full 360 degree range of motion.



SNOW MANAGEMENT

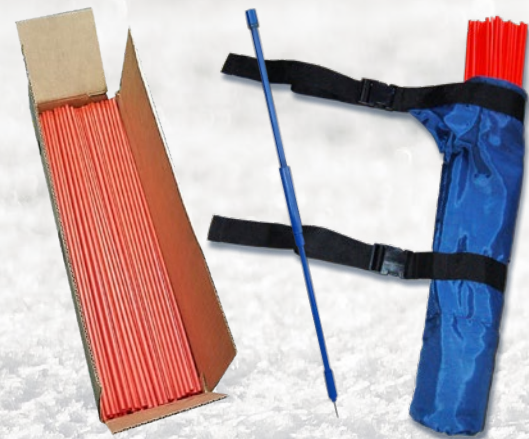

SNOW STAKE SYSTEM

STAY ON TRACK ALL SEASON

KAGE developed this Pounder & Quiver Kit to address the shortcomings of conventional snow stakes. The KAGE Pounder punches a perfect hole for the marker stake. The 3 lb. slide hammer can punch through the toughest soils and even road base gravel.

The Quiver features high-quality nylon material and carries 120 stakes up to 32" long. Strap the quiver to your leg and waist using the two 2" wide straps and industrial strength buckles.

Our Snow Plow Stakes are made of a durable polymer blend which readily rebounds after impact, even in sub-zero temperatures. Available in 26", 32" and 36" lengths.

Replacement tips are available.



BUDDYSTRAP

MINIMIZE BACK STRAIN

The BuddyStrap includes many features that make what was previously a chore, fun! A major benefit of the strap is that it's universal, so you can enhance any D-handled snow shovel in 5 minutes, saving you time, money, and back strain.

Simply attach the strap to the shovel and you can sling it over your shoulder for hands-free carrying. For high-speed commercial applications, the one-handed on and off design allows for easy access.

The strap does not interfere with stacking or storage, so when it's time to put your shovel away, you can do so with ease. The durable seatbelt material resists damage and abuse, and with reinforced stitching and grommets, the heavy duty strap won't tear or weather.



POLY ROTOR PADDLES

KICK MORE SNOW... LONGER

Single-stage snow blowers are a crucial part of your snow removal business. It's hard enough to keep them maintained without the frequent paddle and scraper bar replacement due to normal wear. Compared to rubber paddles, Poly Rotor Blades last up to 4 times longer, produce a cleaner wear edge and sell for the same price.

Keeps its edge as it wears, cutting down to the pavement and cleaning more efficiently.



SNOWBLAZE SHOVEL

CLEAR SNOW MORE EFFICIENTLY

The SnowBlaze revolutionizes the way that commercial contractors and home-owners alike are able to remove mass quantities of snow. Clearing long stretches of sidewalk, or even driveways is easiest if you can 'windrow' the snow. By 'plowing' the snow to one side while pushing it forward, you are displacing the snow in two directions, and containing the dribbles to one side. The flip-stick used for windrowing tucks up and out of the way when not in use and does not interfere with pushing, back-dragging, or lifting the snow.

Utilizes a steel cutting edge that is easily removable and replaceable. It is also supported by an aluminum backing bar to help keep the edge straight.



PLOW ACCESSORIES

WINGLINE™ LASER PLOW GUIDE PATENT PENDING



SNOWFIRE/
SKIDSTEER
SNOWFIRE/
COMPACTS
SNOWSTORM
SHADOWBLADE
TRACTOR
MOUNTS
KAGEKLAWZ
LIQUORAGE
ADVANTEDGE
WHEELKADY
SNOW
MANAGEMENT
PLOW
ACCESSORIES



POLYURETHANE CUTTING EDGE

The Polyurethane Cutting Edge is useful when plowing delicate surfaces such as decorative concrete and pavers, or seal-coating. In our experience, this proprietary blend of polyurethanes outlasts rubber, and even steel in some cases without damaging the plowing surface. The blade is 1 1/2 inches thick, pre-drilled and the optional kit comes with a steel support strip and extra long carriage bolts for easy installation.



CURB-GUARD KIT

Optional curb guard kit helps reduce wear to the trip edge. Clean curb lines are crucial, but don't wear out your plow in the process! The curb guards are sold as a kit, and they are able to transpose so that you get double the wear.

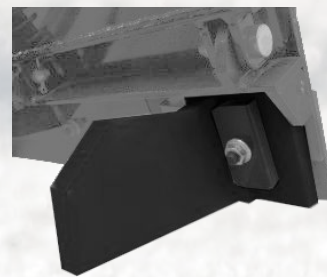

BACK DRAG KIT

The Back Drag Kit manufactured exclusively by KAGE Innovation is designed to fit any 6" to 8" snow plow cutting edge machine with a highway punch bolt hole pattern. It also works great with trip-edge plows and when you're angling snow away from curbs.

The entire kit weighs 10 pounds and it's built from the same uniquely blended polyurethane material used in our Poly Cutting Edges and Poly Skids. It's far more durable and will last considerably longer than rubber.



PLOW GUIDE

High visibility plow guides keep you on track during plow time and help prevent landscape and curb damage. Easy to replace and universal to all KAGE plows.



WINGLINE™ LASER PLOW GUIDE PATENT PENDING

The WingLine™ lets you know where your wing plow trailing edge will be before you get there to avoid potential plow damage and reduce downtime. The WingLine also alerts the driver when the wing plow is down. With the low impact design, the laser plow guide is easy to install and will help protect your equipment and operators for years to come.

The KAGE Advantage:

- >Easy to install
- >Inexpensive
- >Reduce plow damage and downtime



TO ORDER CALL 651-433-4628, OR GO ONLINE: KAGEINNOVATION.COM

SNOWFIRE SPECS

SNOWBLADE					
For Machines Weighing 5,000 lbs.	SB72/LB72	SB96/LB96	SB108/LB108	SB120/LB120	SB144/LB144
Blade Width	6'	8'	9'	10'	12'
Blade Width at Full Angle	59"	79"	88-1/2"	98-1/4"	125"
Oscillation (Degrees/Inch) Each End	6° / 7-1/2"	6° / 10"	6° / 11-1/4"	6° / 12-1/2"	6° / 15"
Moldboard Radius	15-1/2"				
Moldboard Gauge/Steel Grade	10 gals. / Grade 50				
Universal Skid Steer Attachment Guide	Standard				
Trip Springs	4 Compression	4 Compression	4 Compression	4 Compression	8 Compression
Machine Size Recommendation	5,000 +	6,000 +	6,500 +	7,000 +	9,000 +
Cutting Edge	5/8" x 6" High Carbon				
Cross-Over Relief Valve	Standard				
Pivot Frame Length	Shortened (25")		Standard Length (31")		
Weight	906 lbs.	1,031 lbs.	1,087 lbs.	1,147 lbs.	1,651 lbs.
Cylinders	1-1/2" Rod	1-1/2" Rod	1-1/2" Rod	1-1/2" Rod	2" Rod
Blade Height	31-1/8"				

SNOWKAGE					
For Machines Weighing 5,000 lbs.	SB72/LB72	SB96/LB96	SB108/LB108	SB120/LB120	SB144/LB144
Overall Height	36 3/4"				
Overall Width	80"	104"	116"	128"	151-1/2"
Replacement Side Panels	YES				
Hook Thickness (Skid Steer Only)	1-1/2"				
Replacement Polyurethane Skids	Yes				
Unit Weight	366 lbs.	442 lb.			
Machine Size Recommendation	5,000 +	6,000 +	6,500 +	7,000 +	9,000 +
Overall Width at 35° Angle	85-5/8"	105-3/8"	115-1/4"	125-1/8"	144-3/4"

SNOWFIRE SYSTEM					
For Machines Weighing 5,000 lbs.	SBK72/LBK72	SBK96/LBK96	SBK108/LBK108	SBK120/LBK120	SBK144/LBK144
Total Weight (Blade & Box)	1,272 lbs.	1,473 lbs.	1,529 lbs.	1,589 lbs.	2,093 lbs.

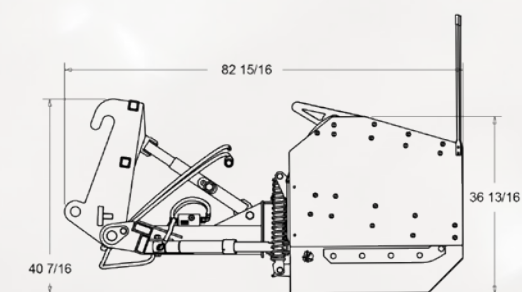
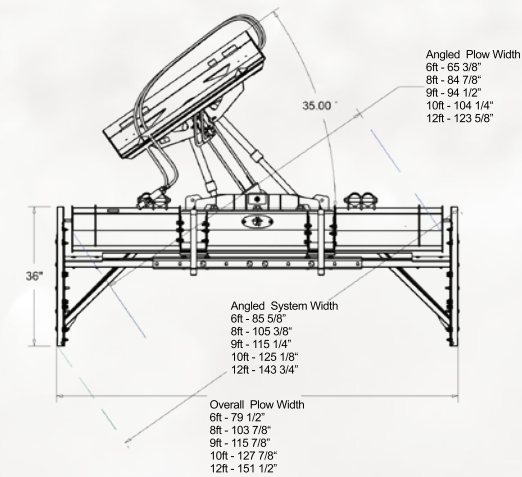
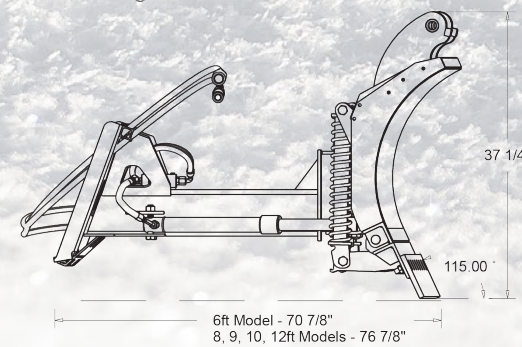
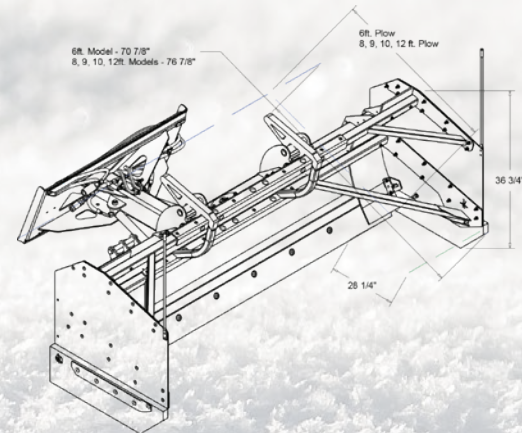

SNOWSTORM SPECS

SNOWBLADE			
For Machines Weighing 15,000-30,000 lbs.	KBSS10	KBSS12	KBSS14
Blade Width	10'	12'	14'
Angle	36 Degrees		
Blade Width at Full Angle	97"	116-1/2"	136"
Oscillation (Degrees/Inch) Each End	6° / 12-1/2"	6° / 15"	6° / 17-1/2"
Moldboard Gauge/Steel Grade	10 gals. / Grade 50		
Loader Quick Attach	See Page 28		
Trip Springs	8 Compressions		
Cutting Edge	(2 pc.) 5/8" x 8" x 5'	(2 pc.) 5/8" x 8" x 6'	(2 pc.) 5/8" x 8" x 7'
Hydraulic Cross-Over Relief Valve	Standard		
Pivot Frame Length	48"		
Weight	2,282 lbs.	2,375 lbs.	2,468 lbs.
Cylinders (2)	(2) 3" Bore 1-1/2" Rod		
Blade Height	36"		
Electric/Hydraulic Valve Kit	12V/24V		

SNOWKAGE			
For Machines Weighing 15,000-30,000 lbs.	KBSS10	KBSS12	KBSS14
Overall Height	40"		
Overall Width	143"	155"	179-1/2"
Overall Width at Full Angle	131"	150-1/2"	169-3/4"
Approximate Capacity	12 yds. +	14 yds. +	18 yds. +
Replaceable Polyurethane Skids	2" x 10" x 42"		

SNOWSTORM SYSTEM			
For Machines Weighing 15,000-30,000 lbs.	KBSS10-XL	KBSS12-XL	KBSS14-XL
Total Weight (Blade & Box)	3,088 lbs.	3,181 lbs.	3,274 lbs.

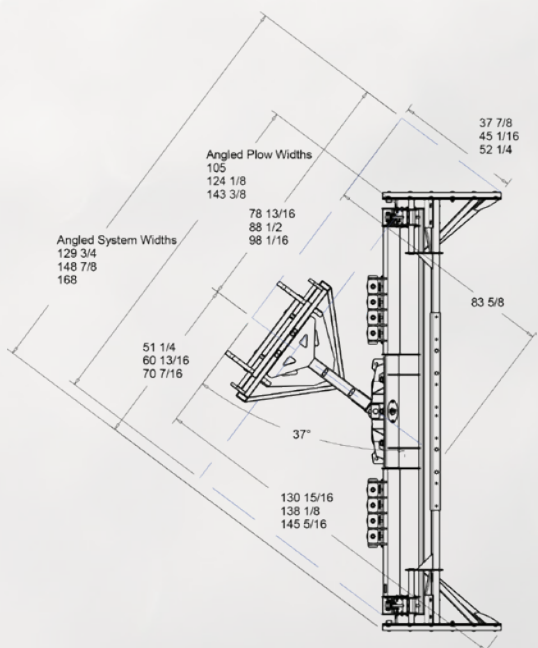
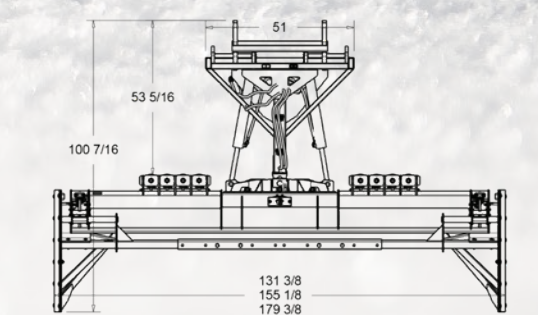
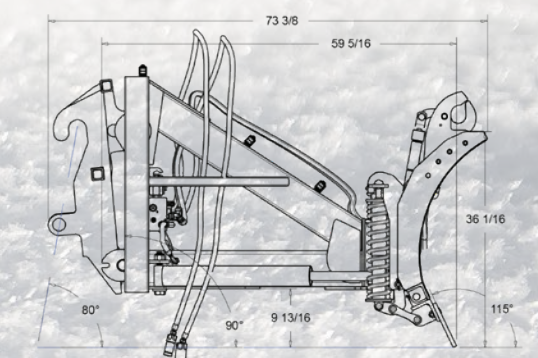
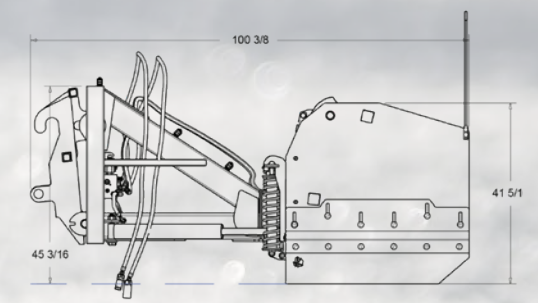

SNOWFIRE QUICK ATTACH SPECS

SNOWSTORM QUICK ATTACH SPECS

SNOWFIRE QUICK ATTACH DIMENSIONS									
Coupler	KAGE Part #	A (in inches)	B (in inches)	C (in inches)	D (in inches)	E (in inches)	X (in inches)	Y (in inches)	Z (in inches)
CAT IT28	28-10	21.875	1.125	2.520	19.937	2.063			
JCB 212	212	25.188	1.000	2.280	19.209	1.760	33.750		
John Deere 310	JD310	38.00	1.000	2.596	20.321	1.825			
JCB 409	409	35.125	1.000	1.650	12.289	1.590			
Takeuchi	TAK506580	37.250	1.125	1.580	12.200	1.580	33.126	1.580	19.690
Case 221	221	9.250	1.000	2.000	20.174	2.025	42.00		
FFC	FFC	47.500	1.000	2.066	24.498	2.060			
JCB 535	535-10	40.375	1.000	2.410	23.652	1.509			
Komatsu WB140	WB140	29.375	1.000	2.030	17.687	1.810			
Volvo 356-20	356-30	39.375	1.000	2.420	24.187	2.000			
New Holland Euro	845	30.250	1.000	1.650	11.750	.920			
Universal Coupler	28-600	-	-	-	-	-			

X: Marks additional width dimensions for ears on different planes than the main ears

Y: Marks diameter for additional holes on combination couplers

Z: Marks additional dimensions for combination couplers

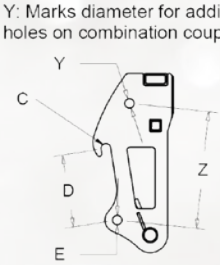
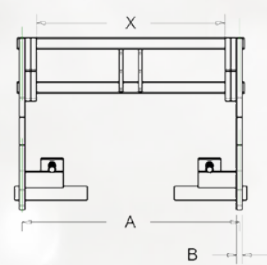

New Holland Euro Universal Coupler

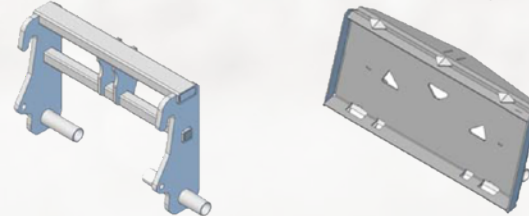

CAT IT28

JCB 212

John Deere 310

Volvo 356-20

Komatsu WB140

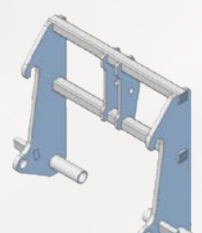
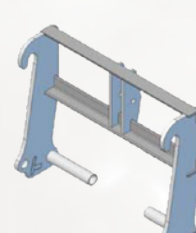
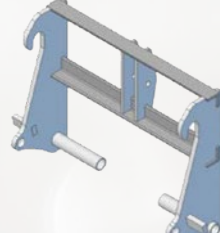
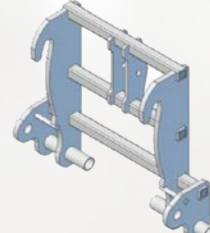

JCB 409; Euro; Volvo L35B; Kubota R530/R630

Takeuchi TW50;65;80

Case 221

JCB 535

FFC QCP-7000

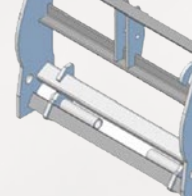
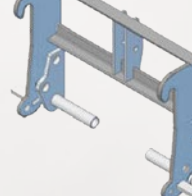
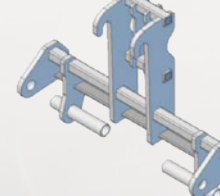
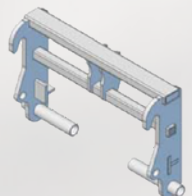

SNOWSTORM QUICK ATTACH DIMENSIONS								
Quick Attach	KAGE Part #	A (in inches)	B (in inches)	C (in inches)	D (in inches)	E (in inches)	X (in inches)	Non Stocked Additional Cost
JRB 416	JRB-416	30.628	1.500	3.001	16.281	2.126		
CAT Fusion	CATFUSION	22.875	1.500	5.000	24.625	3.376		
CAT IT28	CATIT28F-K	22.250	1.500	2.520	19.937	2.062		
Volvo	356-1	39.360	1.000	2.420	24.260	2.000		
Hyundai	HL740TM	22.287	1.500	2.461	19.770	1.992		
Terex	TERSKI863	34.250	4.000	1.969	19.860	2.362	39.250	
JCB 541	JCB541SS	42.484	1.500	2.266	23.687	1.265		
Bobcat 723	B8TC-723	31.250	1.000	3.250	22.437	1.275		
JCB 535	535-200	40.625	1.250	2.437	23.625	1.500		
JRB 418	JRB-418	32.750	1.500	3.030	20.670	2.060		Yes
CAT IT38	CATIT-38	36.250	1.500	3.090	22.790	2.060		Yes
Hi Viz	544HV	39.120	1.500	2.440	24.280	2.064		Yes
ACS 1000/2000	DA90006150							Yes

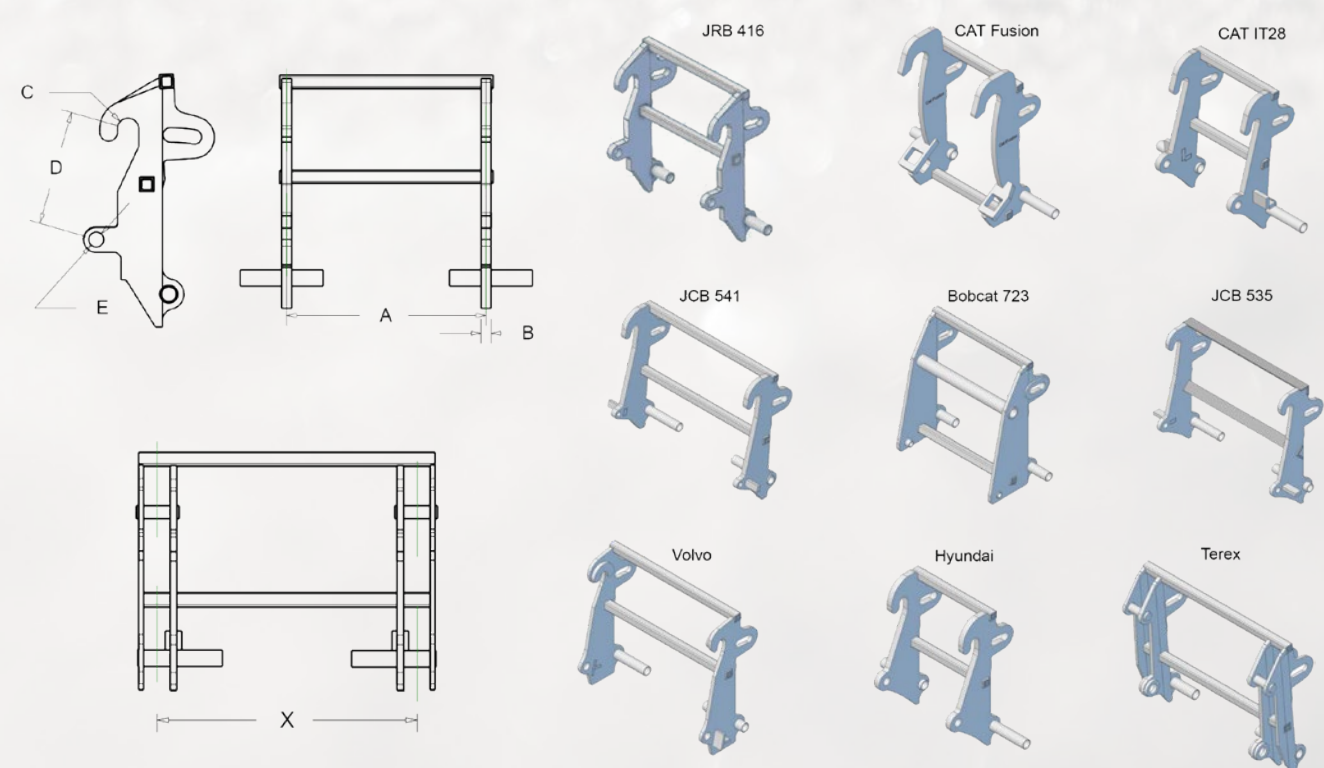

TO ORDER CALL 651-433-4628, OR GO ONLINE: KAGEINNOVATION.COM

SHADOWBLADE SPECS

TRACTOR MOUNT SPECS

SNOWBLADE	
Specifications	Rear Tractor Snow Plow Recommendations
Weight KMX9 (Standard Assembly) - 1,620 lbs.	1 Rear Auxiliary with constant flow (detent)
Weight Optional 17 Degree Wing Extension - 102 lbs.	Cat II 3-point hitch
Weight Optional Straight Wing Extension - 102 lbs.	Recommended tractor weight no less than 9,500 lbs
Operating Voltage - 12VDC	
Operating Current - <20 amp	
Optional Laser Beam Classification - IIIIR	
Moldboard Height - 33 ins.	

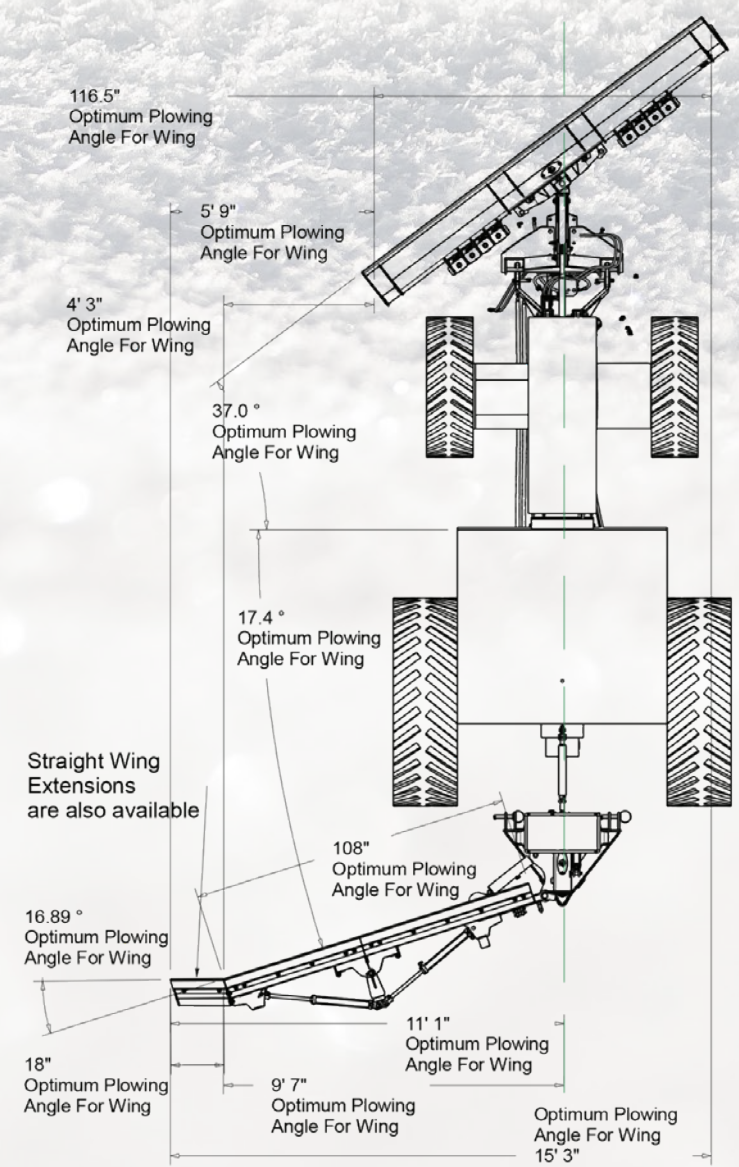
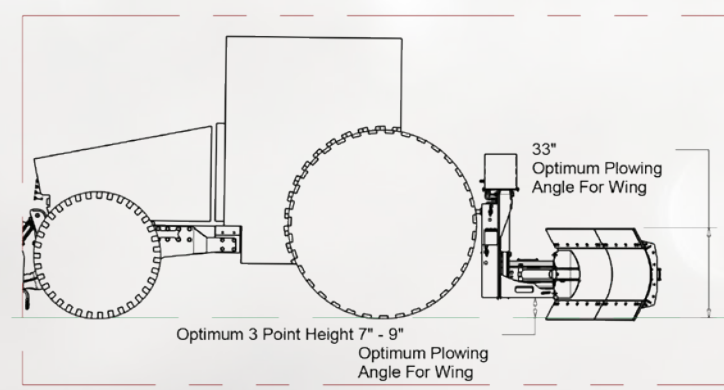
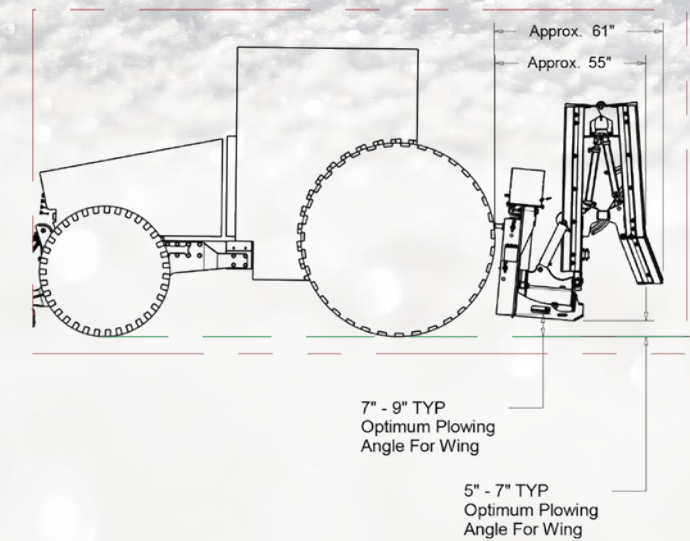

UNDERCARRIAGE KITS				
Make/Model Tractor	Plow Hitch Style	Lift Cylinders	Tractor Requirements	Recommended System
John Deere® - 6430/6125R/6125M/6115M	Cat II 3-Point	(2) 3"x10"	Loader Valve/Joystick in Cab	10', 12', 14' SS
John Deere® - 6410M/6150M			One Auxiliary (mid or rear)	
John Deere® - 5095M/5105M/5100M/5115M/5085M			Loader Valve/Joystick in Cab	10' SS or 12' SF
John Deere® - 5101E/5083E/5085E*			One Auxiliary (mid or rear)	6', 8', 9', 10', 12' SF or 10' SS
John Deere® - 5075E			800-1,000 Lbs Counterweight Recommended	
John Deere® - 6101D/6115D/6130D/6140D **			Joystick in Cab	10', 12', 14' SS
John Deere® - 6105D/6140D	One Auxiliary (mid or rear)			
KUBOTA® - L4240/L4740/L5040/L5240/L5740/L6060	2-Pin Style	(1) 2-1/2"x16 Cylinders	Joystick in Cab W/3rd Auxiliary Option	8' SF
JOHN DEERE® - 4120/4320/4520/4720			800-1,000 Lbs Counterweight Recommended	6' SF
JOHN DEERE® - 4066R				
KUBOTA® - M8540/M9540/M8560/M9960/M5	Cat II 3-Point	(2) 3"x10" Cylinders	Loader Valve/Joystick in Cab	10' SS or 12' SF
KUBOTA® M135X			One Auxiliary (mid or rear)	10', 12', 14' SS
KUBOTA® M110GX				
KUBOTA® M135GX/M6				
Universal Kit (requires end-user fabrication)			Loader Valve/Joystick in Cab One Auxiliary (mid or rear) 800-1,000 Lbs Counterweight Recommended	8', 9', 10', 12' SF or 10', 12' SS

* Verify for all models. Ask your salesperson for more information
** Excludes Tier 4 engines

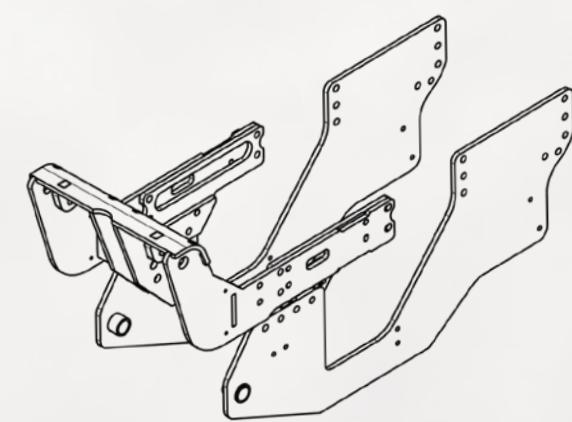

These measurements must be confirmed, as the tractor's frame will be longer on some models.

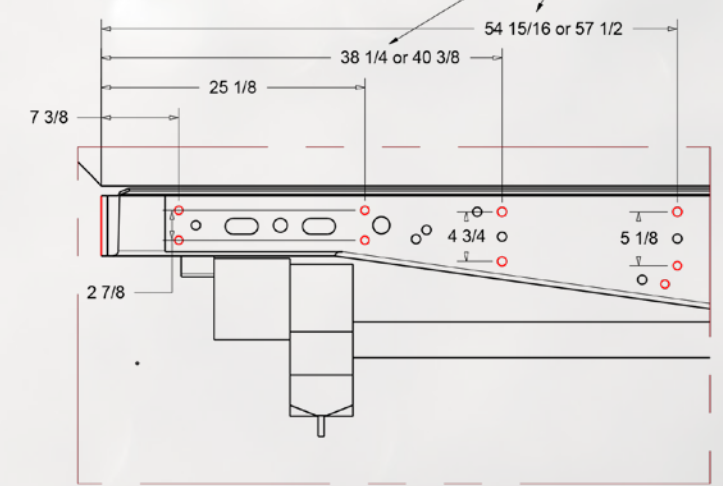

KAGEKLAWZ SPECS

LIQUIDRAGE SPECS

KAGEKLAWZ APPLICATION GUIDE				
STOCK TIRE SIZE				
10 x 16.5 (stock tire is about 30-32" tall)		12 x 16.5 (stock tire is about 33" tall)		
KAGE KLAWZ MODELS				
225 Kit	245 Kit*	255 Kit**	245 Kit	255 Kit*
FENDER INTERFERENCE				
3" Fender Clearance Required		6" Fender Clearance Required	3" Fender Clearance Required	
SPEED ENHANCEMENT				
No Significant Increase	11% Increase (~1.5 mph)	11% Increase (~2.1 mph)	No Significant Increase	11% Increase (~2.1 mph)

*NOTE: This configuration increases the overall height of the machine by approximately 1.5"

**NOTE: This configuration increases the overall height of the machine by approximately 3"

KAGEKLAWZ SPECIFICATIONS				
SNOW TIRE KIT	Model 225	Model 245*	Model 255	Model 255**
Size	225/70R19.5	245/70R19.5	255/70R22.5	255/70R22.5
Ply Rating / Load Range	12	14	16	16
Capacity Per Set of 4	14,560 lbs.	18,160 lbs.	22,040 lbs.	22,040 lbs.
Pilot Hole Diameter	6"	6"	6"	9" - Bobcat Specific
Bolt Pattern	8 x 8"	8 x 8"	8 x 8"	8 x 10.25"
Wheel Size	19.5 x 6.75	19.5 x 6.75	22.5 x 8.25	22.5 x 8.25
Tire Height	32.4	33.4	36.6	36.6
Overall Tire Width	8.8	9.6	9.8	9.8
Offset	POS 1.25"	POS 1.25"	NEG 1.5"	ZERO
Tread Width	7.1	7.5	7.8	7.8
Product Number	225KIT	245KIT	255KIT	255LGKIT

*NOTE: Most common tire kit

**NOTE: Bobcat Specific (S750, S770, S850, A300)

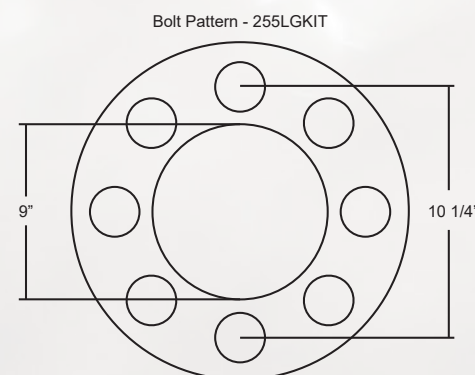
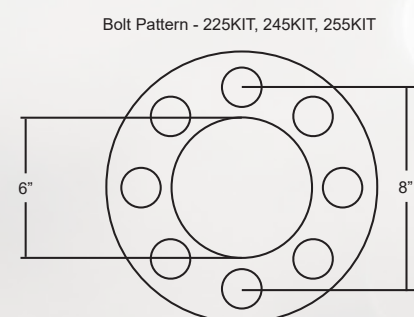

LIQUIDRAGE	
Specifications	
Mounts	Skid Steer/Cat II 3-Point
Pump	Hydraulic
Internal Debris Filter	Standard
Dump Valve	Standard
Quick Disconnect Hydraulic Couplers	Skid Steer Flat Face Standard
Quick Disconnect Ag Hydraulic Couplers	EXTRA
Nozzle Type	(5) 6 Stream Penetrating Nozzles
Tank Capacity	150 gals.
Pressure Regulator with Gauge	Standard/Manual
Spray Width	Adjustable 5' - 10'
Weight Lbs (loaded/empty)	2067/417

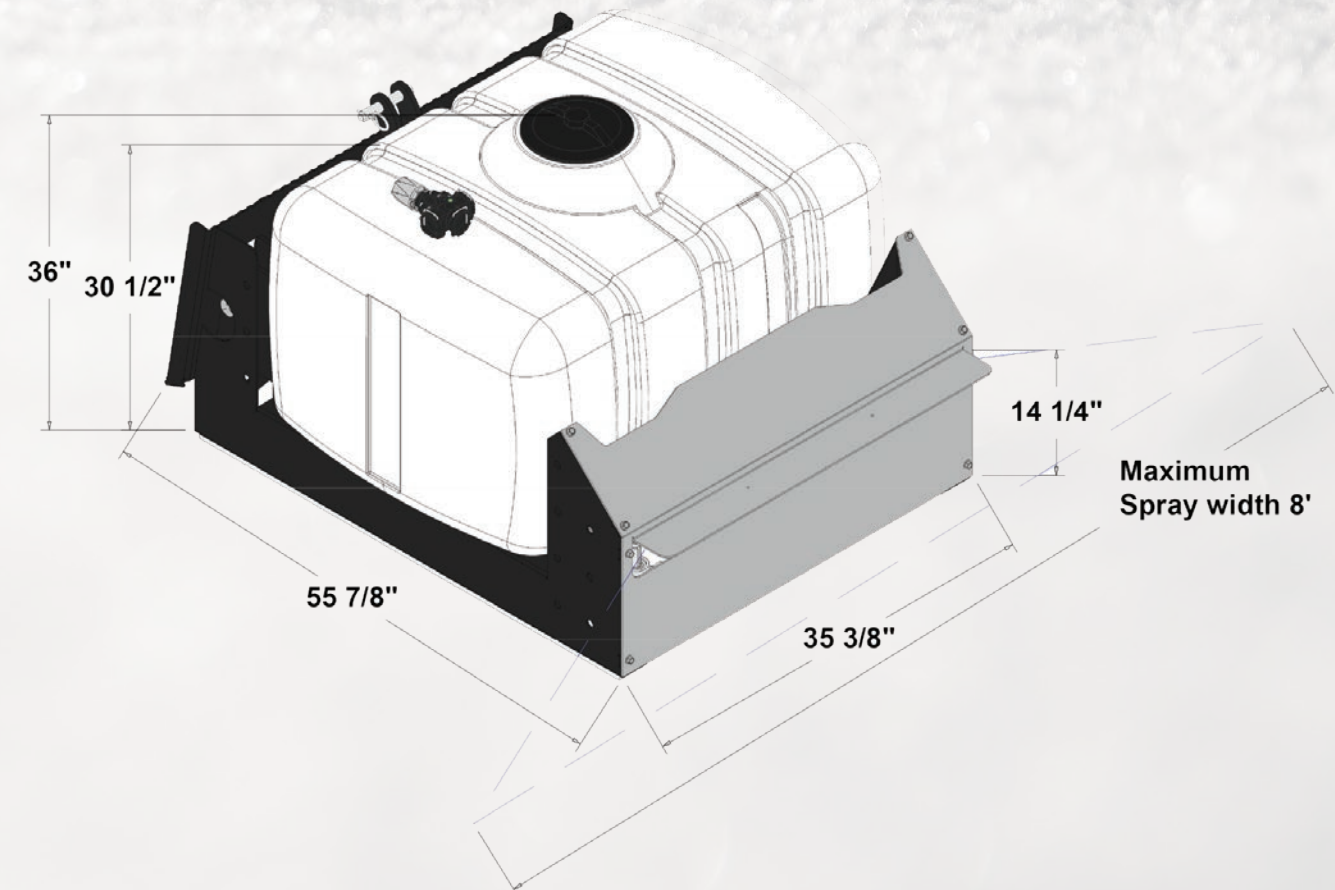

TO ORDER CALL 651-433-4628, OR GO ONLINE: KAGEINNOVATION.COM

ADVANTEDGE SPECS

WHEELKADDY SPECS

ADVANTEDGE		
Part Name	Part Number	Length
SF AdvantEdge 6' Complete Kit	SFAE6	6 feet
SF AdvantEdge 8' Complete Kit	SFAE8	8 feet
SF AdvantEdge 9' Complete Kit	SFAE9	9 feet
SF AdvantEdge 10' Complete Kit	SFAE10	10 feet
SS AdvantEdge 12' Complete Kit	SSAE12	12 feet
SS AdvantEdge 14' Complete Kit	SSAE14	14 feet
SF AdvantEdge 2' Segment	SF2S	2 feet
SF AdvantEdge 3' Segment	SF3S	3 feet
SF AdvantEdge 4' Segment	SF4S	4 feet
SF AdvantEdge 5' Segment	SF5S	5 feet
AdvantEdge Replacement Cutting Edge 18"	SBC18FE	18 inches
AdvantEdge Replacement Cutting Edge 24"	SBC24FE	24 inches
Edge Extension 18	18EEKIT	18 inches
Edge Extension 24	24EEKIT	24 inches

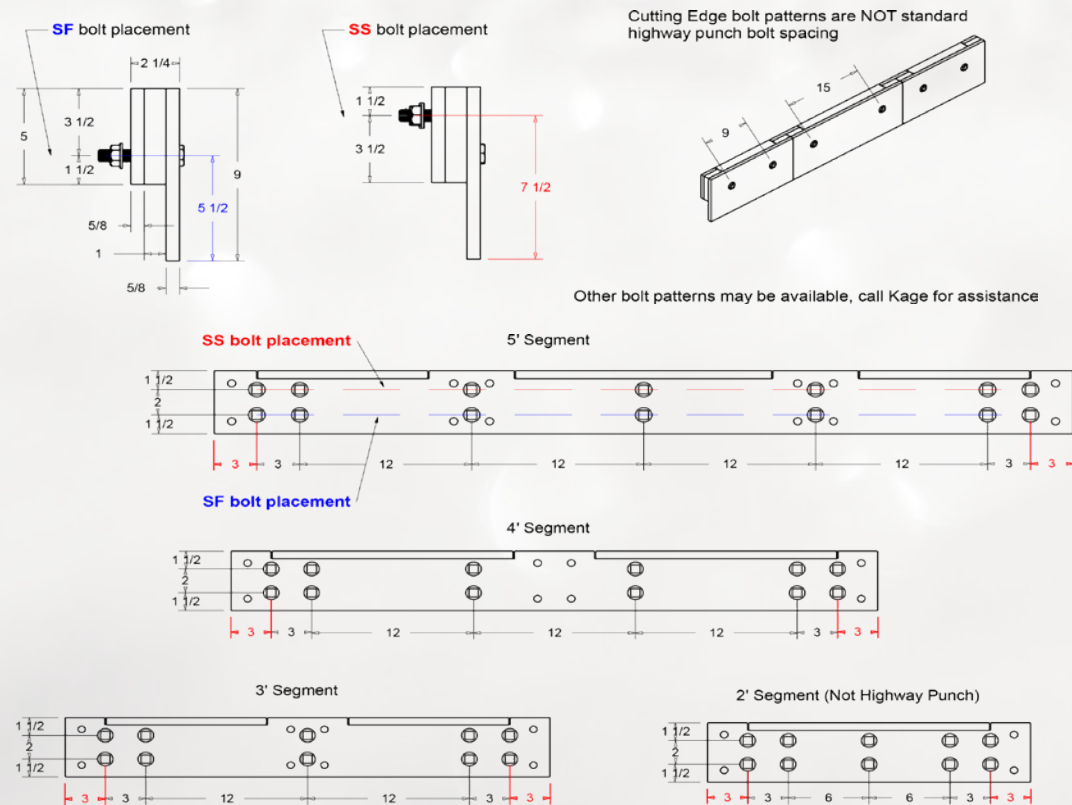

WHEELKADDY FEATURE COMPARISON			
	250 Series	500 Series	360 Series
Soft-Ride Suspension		✓	✓
3-Piece Wheels (quick tire change)	✓	✓	✓
360 Degree Pivot Action			✓
Grade 50 Steel Platform	✓	✓	✓
Quick Release Mount	✓	✓	✓
Tapered Roller Bearings	✓	✓	✓
Grease-able P-T-O Pivots	✓	✓	✓
Platform Pitch Adjustment	✓	✓	✓
Standard Tire Diameter	13"	13"	10"-11"

WHEELKADDY SERIES SPECS			
	250 Series	500 Series	360 Series - 10" tires
Tire Size	13" (13 x 5.00-6)	13" (13 x 5.00-6)	10" (410/350-4)
Length Adjust	Adjustable 20" to 26"	Adjustable	Adjustable 21" to 25"
Platform Height	3"	3"	1 3/4"
Tire Width	4 1/2"	4 1/2"	3 7/8"
Platform Width	26 3/4"	26 3/4"	26 1/4"
Max. Mount Height	15 3/8"	15 3/8"	13 1/2"
Min. Mount Height	9 3/8"	9 3/8"	12"
Pitch Adjust	N/A	N/A	Adjustable +/- 3 Degrees from level height
Weight	48 lbs.	48 lbs.	46.8 lbs.
Wheel Bearing Type	Tapered Roller Bearing	Tapered Roller Bearing	Tapered Roller Bearing
Oscillation	Yes	Yes	Yes
Tire (Tubed/Tubeless)	Tubed	Tubed	Tubed
360 Degree Pivot	N/A	N/A	Yes
Suspension	N/A	Yes	Yes

TO ORDER CALL 651-433-4628, OR GO ONLINE: KAGEINNOVATION.COM



KAGE Innovation, LLC

KAGEInnovation.com | 651-433-4628 | fax 651-344-0887

502 Simmon Drive
Osceola, WI 54020

PATENT INFORMATION

SNOWFIRE & SNOWSTORM - Patent #7,654,016; #7,788,829; #7,941,947; #2,707,963; #2,574,587
SHADOWBLADE - Patent # 8,776,406