



## FEATURES

- > Adaptable to skid steers, ag tractors & ATVs
- > 150 Gallon Capacity
- > Fully enclosed design protects critical components
- > Attaches directly to CAT II 3-Point Hitch



## KAGE ADVANTAGE

Anti-icing liquids are becoming all the rage. Use fewer solids to get the job done, and provide your customers with top-notch service.

To maximize versatility, the LiquidRage is designed to accommodate spring and summer applications. By using the KAGE summer kit, the LiquidRage becomes a broadleaf exterminator weapon.

The Liquid Rage enables you to seamlessly apply brine and other chemicals from your skid-loader, tractor, and UTV without buying expensive adapters and other equipment.



(Shown with optional hose reel, brine mixer & broadcast kit)



# LIQUID RAGE SPECIFICATIONS

## OPTIONAL KITS

### BROADCAST KIT



### BRINE MIXER



### HOSE REEL KIT



## WHY USE LIQUID DE-ICER?

1. Better for turf, soil and ground water
2. Does not bounce off your target coverage area
3. Does not 'plow off'
4. Nearly eliminates tracking into buildings, corrosion, and build up
5. Prevents ice bonding to pavement
6. Easy to pump
7. May include corrosion inhibitors to extend equipment life
8. Pretreatment Requires 10x less resources than salt
9. Works at colder temperatures than salt
10. Begins working immediately

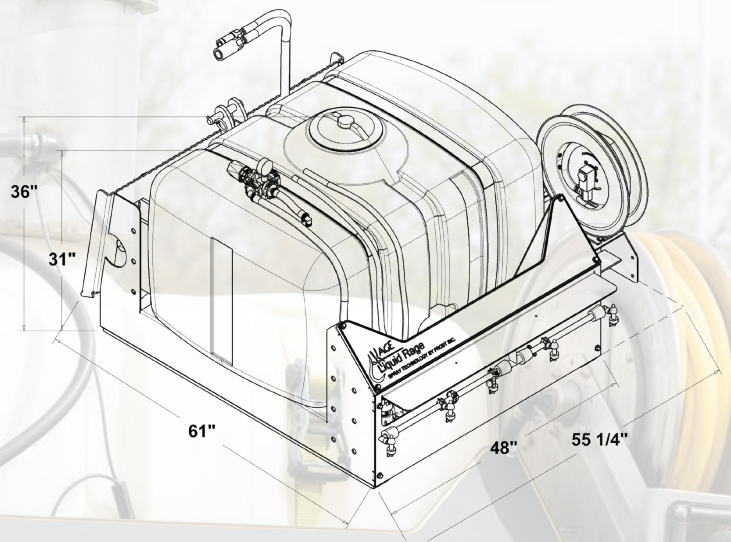
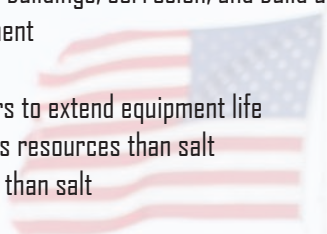

### LIQUIDRAGE

Specifications	
Mounts	Skid-Steer / CAT II 3 Point
Pump	Hydraulic
Internal Debris Filter	Standard
Dump Valve	Standard
Quick Disconnect Hydraulic Couplers	Skid-Steer Flat-Faced Standard
Nozzle Type	(5) B Stream Penetrating Nozzles
Tank Capacity	150 Gallons
Pressure Regulator With Gauge	Standard
Spray Width	Adjustable 5'-10'
(Optional) Broadcast Nozzle	3 Fan Nozzles
Broadcast Nozzle Spray Width	Adjustable 5'-30'

## FEATURES

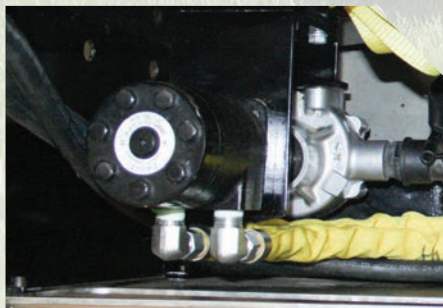

HYDRAULIC DRIVEN FILTERED PUMP



PRESSURE CONTROL



PATENTED 3-POINT SKID STEER ATTACHMENT

TO ORDER CALL 651-433-4628, OR GO ONLINE: [KAGEINNOVATION.COM](http://KAGEINNOVATION.COM)